

TOP

	WIDTH				
No OF HEATERS	2	3	4	5	6
Dimension A (mm)	755	1118	1481	1844	2207

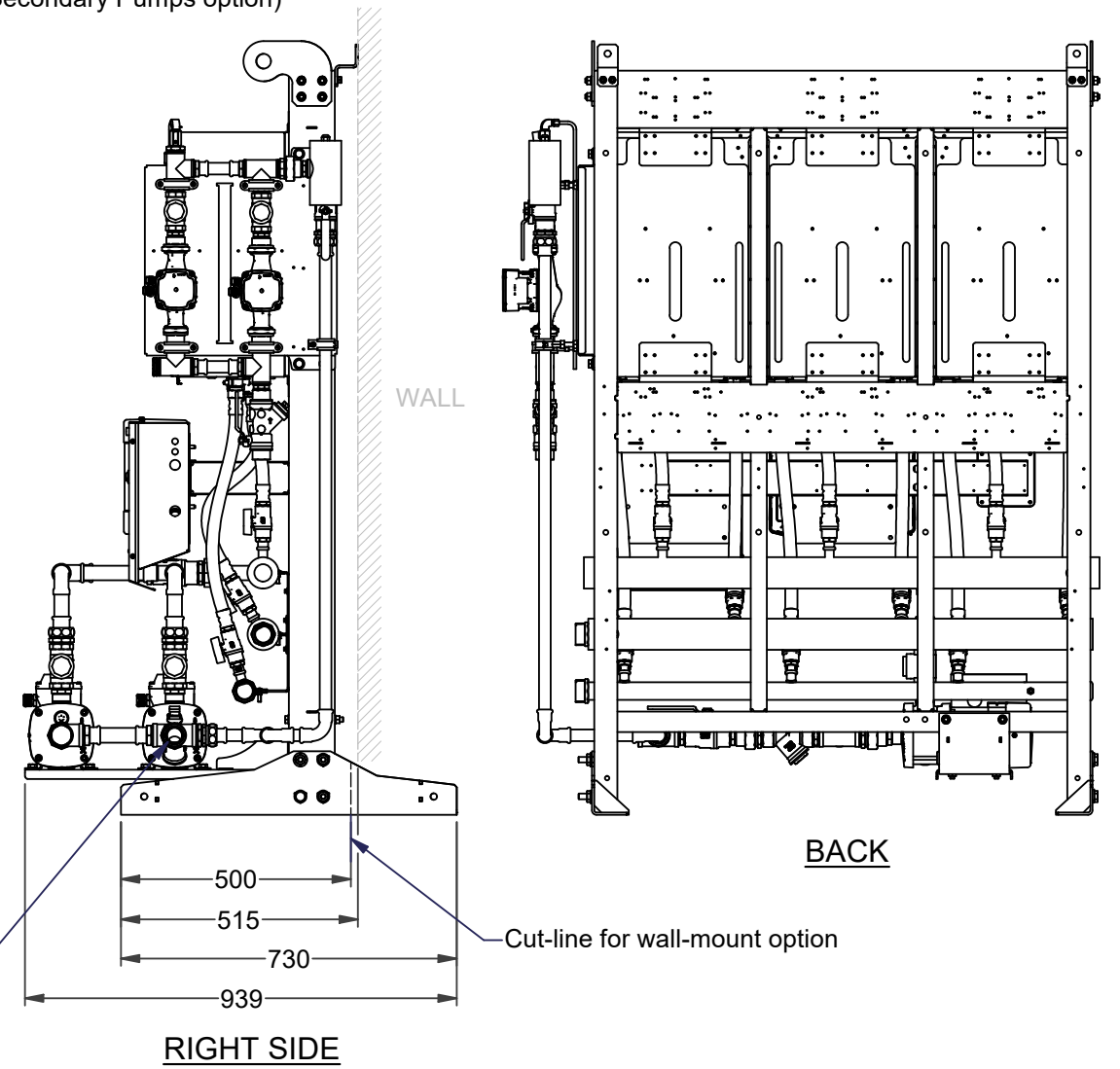
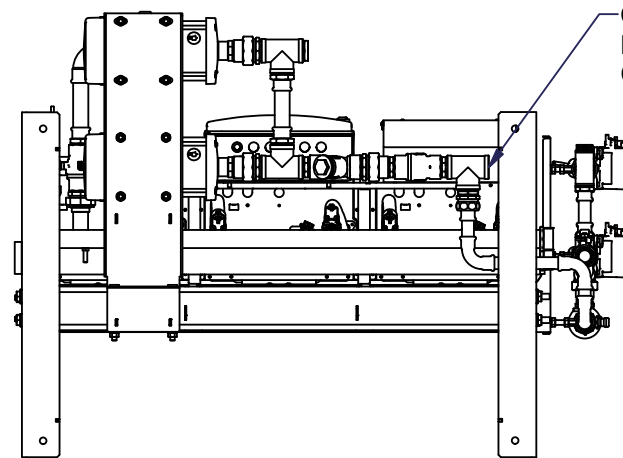
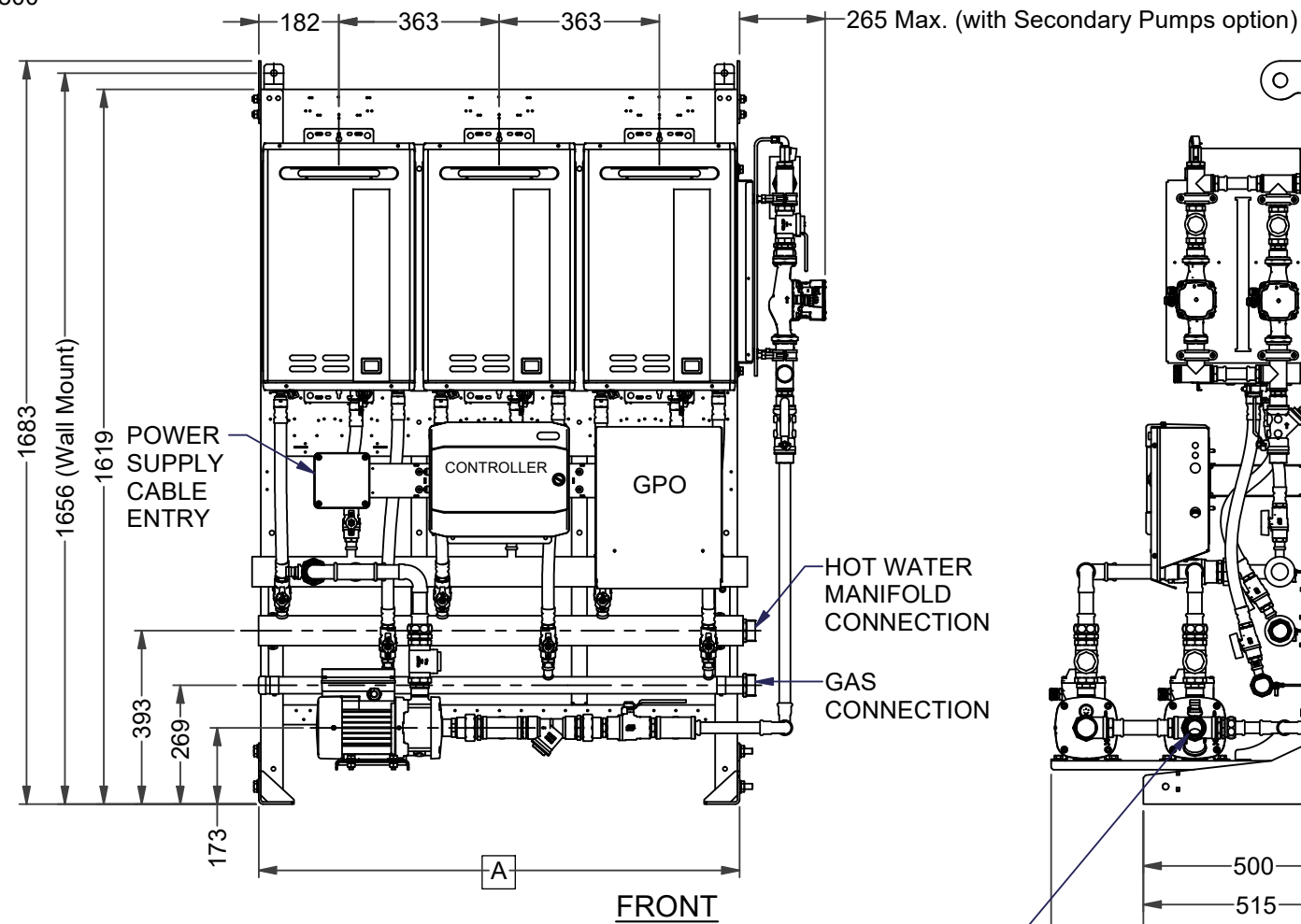
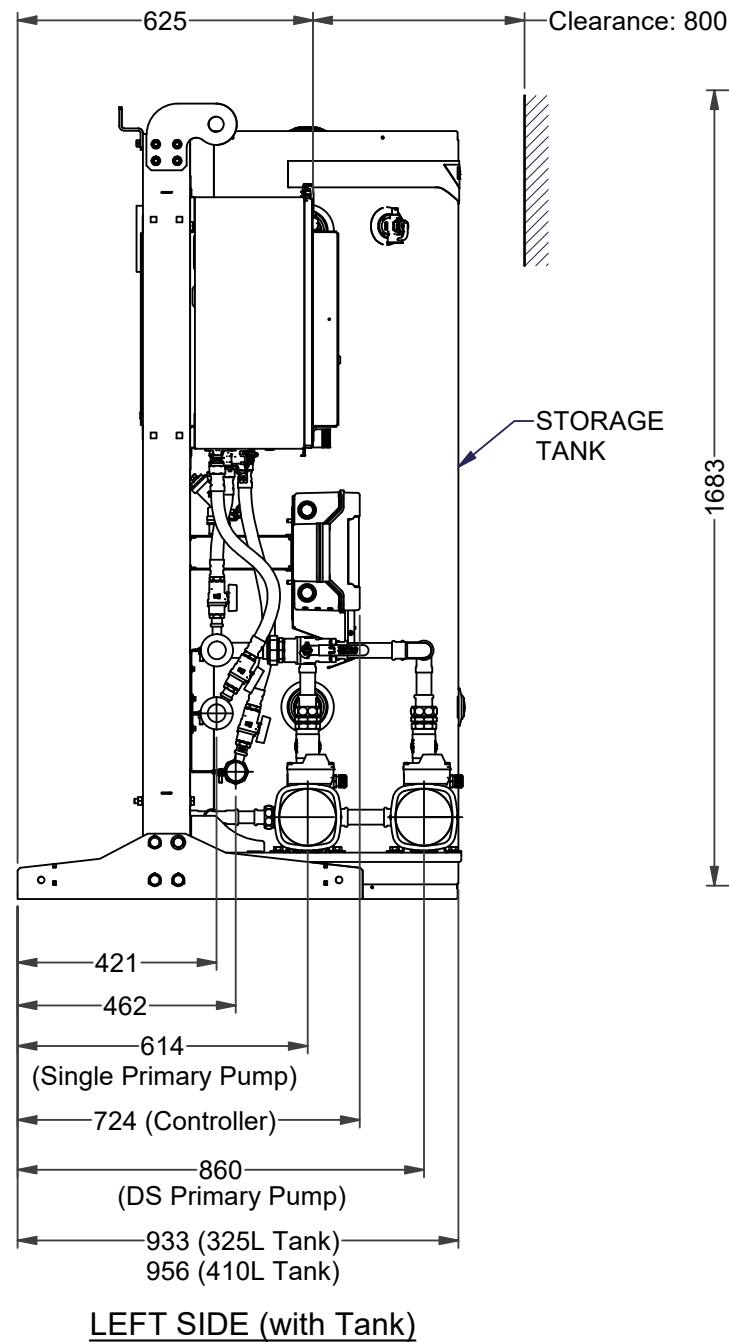

RHEEM AUSTRALIA PTY LTD

This drawing and the information it contains is the exclusive property of: RHEEM AUSTRALIA Pty Ltd. It must not be reproduced, in whole or in part, without written permission from: RHEEM AUSTRALIA Pty Ltd.

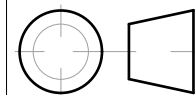

THIRD ANGLE PROJECTION

TOLERANCES UNLESS NOTED OTHERWISE

No (0) Decimals +/- 1.0 mm
 One (1) Decimal +/- 0.5 mm
 Two (2) Decimals +/- 0.25 mm
 Angles +/- 1 Degree

ALL DIMENSIONS IN MILLIMETRES

DO NOT SCALE

PART	AQ00002105	SHT 1 1	A3
DESCRIPTION	TANKPAK SERIES 4 EXTERNAL RANGE		
DRAWN	DATE	PASSED	
AP	18/10/2024	TW	

AM240406	A	DRAWING RELEASED	28/10/24	AP	JP	TW
EPCR	REV	DESCRIPTION	DATE	DSGR	CHKD	APPR